

# NEW TECHNOLOGY TO VARY THE FLOW CHANNEL GAP AT THE EXIT OF AN ANNULAR DIE

Heinz Gross;

Dr. Gross Kunststoff-Verfahrenstechnik, Heinz-gross@t-online.de

## Abstract

Novel simple annular die constructions which allow for an axial shifting of the die in regard to the mandrel open up totally new processing possibilities. Using a special elastic or metallic tilting joint in the dividing area between the basic head and the die facilitates the construction of annular heads. Tube and pipe dies can be built which give rise to a sensitive change of the flow channel gap at the exit of the die while the process is running. For the first time even a reproducible centering of the die is possible in pipe and tube extrusion. In extrusion blow molding the die can be dynamically tilted while the parison is extracted. Especiall metallic tilting joints allow for the production of totally new heads for the extrusion blow molding process. This leads to a decisive reduction of the complexity of heads. I combination with the novel GWDS technology the complexity of the blow molding process can be reduced. Additionally the wall thickness distribution of blow molded parts can be further improved.

Keywords: circumferencial thickness tolerances, pipe extrusion , extrusion blow molding,

## Introduction

It is state of the art to produce pipes or tubes having the same diameter but a slightly different wall thicknesses without changing the die. In order to achieve the different wanted wall thicknesses the the hall-off speed is simply changed. But as a consequence the molecular orientation also changes with different wall thicknesses. This is often not desired. An optimum die gap is particularly advantageous if the molecular orientation between die and calibrating unit is to be kept low in order, for example, to minimize shrinkage. It would naturally also be desirable if this additional process engineering option did not have to be at the expense of a far more complex head construction, and also the ease of operation and maintenance were not impaired. The tilting technology [2,3] that was developed to allow for a more accurate and specific centering of a head (Fig. 1) has created new boundary condition for being able to also very easily adjust the die gap.

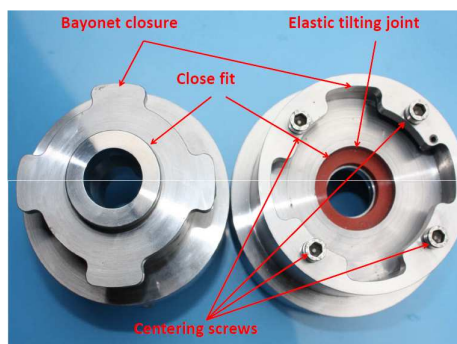

Fig. 1 Disassembled tilting die having a bayonet closure showing the special

bayonet closure and the tilting joint the die and the head

## Tilting technology

With the tilting technology, heat-resistant elastomer seals are used to seal the gap between the head and the die (see Fig. 1). The die is now tilted instead of being shifted as to date in order to center the die in relation to the mandrel. This offers a whole range of crucial benefits compared with the conventional metallic seal. Since the die no longer has to be shifted back and forth, a tighter fit can be created between die and head so that the die can only be installed centrally. The pre-centering of the die that was necessary to date after cleaning a head can thus be eliminated. In order to ensure the reproducible compression of the tilting seal necessary for reliable sealing, it also has a simple bayonet fitting. Eccentric differences in thickness can be reduced by tilting the die. This is currently performed in a transitional phase using axially arranged adjusting screws (Fig. 2). The final goal has to be to use a motorized solution so that the centering can be performed from the control cabinet of the line. This immediately allow for a more precise centering, and opens up the possibility that an optimized position, once found, can be exactly reproduced at any time. After cleaning of the head, the die can be moved during the restart to exactly the same position as used during the last production. During extrusion blow-molding, a motorized adjustment system allows the die to be tilted dynamically even during the discharge of the parison in order, for example, to take account



Fig.2 Tulting die in operation showing one of the small axially arranged adjusting screws having a special fine pitch for a sensitive tilting of the die

of the different stretch ratios on the inside and outside of the curve when producing curved tubes and pipes (Fig. 3). When tilting the die, the elastomer seal is simply compressed slightly more on the side on which the die gap is to be reduced. The gap of the flow channel on the opposite side is accordingly increased by the same amount.

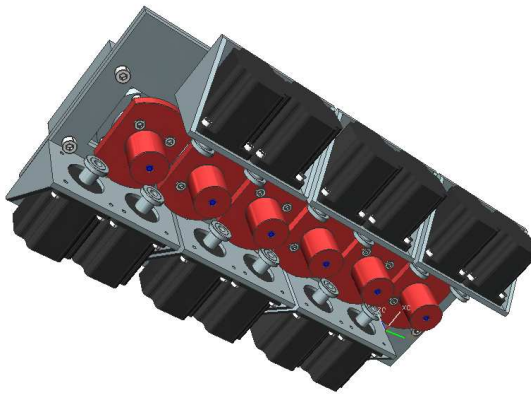

Fig. 3 Unit to retrofit the tilting technology to an existing six cavity head having twelve stepper drives to tilt every die individually

But the tilting technology has not only overcome the weaknesses associated with the conventional centering solution, it has also led to a simplification of the construction of annular dies. This also leads to a reduction in the production costs. Once the concern generally prevailing among experts that an elastomer seal could not be integrated into the flow channel of an extrusion die had been overcome, it was a logical next step to exploit the elasticity of the seal to also adjust the die as a whole relative to the head. And if the principle is then breached that a tube die has to have a parallel discharge zone at the end of the flow channel, the way is open for an adjustment of the die gap. A particular advantage is that the head construction is far simpler compared with the generally known solutions used in extrusion blow molding.

Although it has undisputed process engineering drawbacks [4], it is still quite common in extrusion blow-molding to use heads with a conical mandrel and conical die in order to be able to adjust the die gap. For this either the mandrel or the die is shifted axially over a given distance. A certain leakage has to be accepted, as the moving head section has to be shifted in a bore with a fitting allowance. If the gap of a tube head is to be changed, it is sufficient for only the mandrel to have a conical form while maintaining a cylindrical die. The possible adjustment range of the gap is then dependent on the cone angle of the mandrel end and on the travel distance that can be achieved with the additional compression of the tilting seal.

#### Axially adjustable die

For tubes with the same or at least a similar outside diameter, the bandwidth of desired wall thicknesses is generally fairly small. In practice, travel distances of just a few millimeters are therefore sufficient in order to be able to achieve the required gap variation. If the tilting seal is designed slightly thicker, the seal can be compressed further, starting from the preload necessary to achieve the sealing effect. This can be steplessly achieved using a simple threaded ring. Figure 4 shows a tube die of this type with integrated tilting joint and die gap adjustment. The die is tilted by

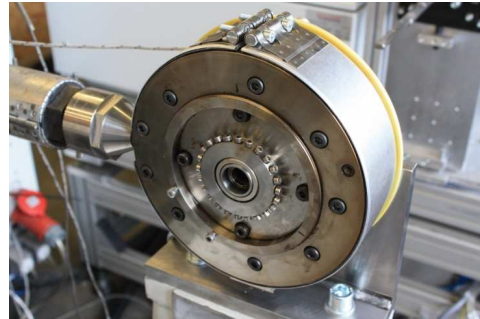

Fig. 4 Side fed tube die having an elastic tilting joint to tilthe die and to shift the die axially in regard to the mandrel and a Flex Ring sleeve to sensitively reduce existing non symmetric thickness differences over the circumference of the tube

means of four axially arranged adjusting screws in the face of the die which act directly on the flanged collar of the die. Between the clamping screws with which the head cover is attached to the head and the centering screws is a threaded ring with which the width of the flow channel can be adjusted. In addition, the head also has a Flex Ring sleeve. Radially arranged adjusting screws allow a limited localized circumferential adjustment of the flow channel gap in order to be able to minimize asymmetric thickness fluctuations. The improved and more precise centering possibility and the localized changing of the flow channel gap using the Flex Ring sleeve thus enable previously

unachieved thickness tolerances to be attained in the tube.

Fig. 5 shows the tube die in operation. The newly designed head also sets standards when it comes to ease of maintenance. Despite the gap adjustment feature, the head can be completely cleaned without having to be removed from the extruder flange. After loosening the bolts with which the head cover is fastened to the main housing of the head, the cover can be removed and the whole flow channel of the head is accessible for cleaning. During this time, the main housing remains flanged to the extruder.

The tilting technology had for a certain time only limited use. The elastic tilting joints can only be used up to operating temperatures of 300 °C. Furthermore the wear resistance of the elastomer

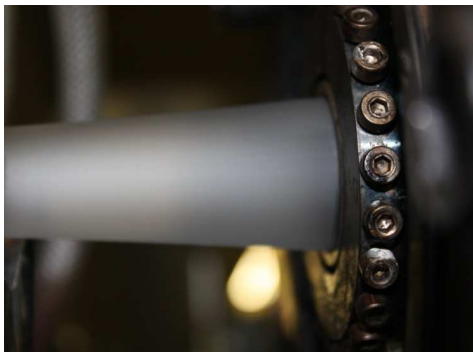

Fig. 5 Tube die with radially arranged screws to optimize the flow channel gap between the Flex Ring sleeve and the mandrel in order to reduce the thickness tolerances in the tube

blend is not sufficient to process compounds with abrasive constituents. However these limits could be overcome, with an alternative metallic tilting seal. This then even allows for a much wider movement of the die in regard to the mandrel. Fig. 6 shows a recently developed advantageous GWDS die for extrusion blow molding which has a metallic tilting joint. Instead of a conventional

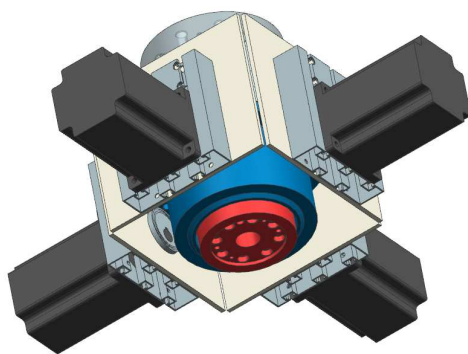

Fig 6 Novel GWDS blow molding head which allows for a further improvement of the thickness distribution of blow molded parts

conical flow channels GWDS dies use a cylindrical ones at the end of the die [4]. Compared to well established conventional production methods GWDS dies create the potential to further improve the wall thickness distribution of every blow molded parts that is produced. Fig. 7 shows as an example the comparison between a small fuel tank that has been produced using the conventional technique (on the bottom) and by using the GWDS-technology (on top). To achieve the convincing result a conventional machine with a solid die and a solid mandrel was used. It is impossible to achieve a comparable good thickness distribution in the tank even when using the well established complex and expensive deformable PWDS- or Flex Ring-systems. Operated by four stepper drives the die

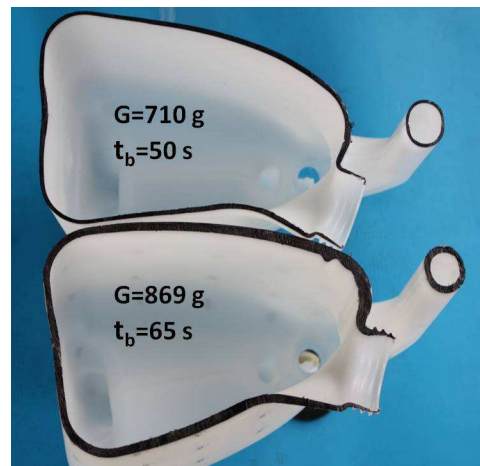

Fig. 7 Wall thickness distribution, weight (G) and blowing or cooling time ( $t_b$ ) of a tanks that have been produced conventionally (on the bottom) and with the GWDS-technology

shown in Fig 6 can be tilted in order to center it. But in the same time it can be shifted axially by 20 mm in order to change the relative position between the die and the mandrel. The big realized adjusting path is of importance as the GWDS technology requires longer adjusting paths as conventional blow molding dies.

## References

- 1 Lachhammer, D.: Einsparungen durch innovative Konzepte [Savings through innovative concepts]. Extrusion journal, Issue 7/2006, pp. 21-24
- 2 Gross, H.: Tilting die. German Patent No. 10 2009 058 361 B3, granted on 1 June 2010
- 3 Gross, H.: Kipptechnologie verbessert nicht nur das Zentrieren [Tilting technology improves centering and other features]. Kunststoffe, Carl Hanser Verlag Munich Vienna, Volume 102, Issue 3/2012, pp. 42-44

- 4 Gross, H.: Muss eine Blasformdüse im Austrittsbereich konisch sein? [Does a blow-molding die have to be conical in the discharge section? *Kunststoffe*, Carl Hanser Verlag Munich Vienna, Volume 102, Issue 9/2012, pp. 58-64